

Systems



TM1

Vibration monitoring equipment, single/dual channel



تجهیزات انرژی باختر

TAJHIZ ENERGY BAKHTAR

CE UK
CA



CEMB

BALANCING MACHINES



TM1

Vibration monitoring equipment,
single/dual channel

► Function

The TM1 equipment continuously measures the vibrations of rotating machines by supplying analog outputs (for interfaces to PLC or DCS) or digital outputs (alarm and trip contacts) with the display on a digital readout of the found value. The equipment can be connected to other instruments (max. 32) via serial line RS485 or to a PC (through appropriate interface) for setting and reading the stored data by the various measuring parameters.

► Main characteristics

The TM1 instrument has been designed and implemented with the latest digital technologies which have allowed to improve the flexibility and performance of the system, by reducing its overall dimensions and simplifying the procedures for installation, setting and modification of all the operating parameters.

The instrument can be interfaced to 1 or 2 sensors (velocity transducers or acceleration transducers) besides with two phase reference transducers.

Digital readout of the vibration value allows the operator to have an immediate check of the vibratory state of the machine during set-up operations.

The control panel is provided with various buttons

► Typical applications

Testing of the vibration of one or two channels of any type of rotating machine (motors, fans, compressors, turbines, pumps, etc.). It is normally installed near the machine and performs all the functions required for protection and monitoring: measurement, protection, alarm signalling, interfaceability with supervisory system, self-diagnostics.

for presetting the operating parameters of the instrument (selection of: measuring unit, alarm thresholds, alarm time delay, threshold multiplier, by-pass) as well as LED's for displaying the status regarding alarm, self-diagnostics and BNC sockets for connection to a vibration analyzer. The instrument is also provided with a serial link RS485 for transferring stored data and settings of all operating parameters of the instrument by a PC.

The TM1 equipment can be installed in an electrical cabinet (fixing on Din rail) or inside a junction box positioned next to the machine being monitored.

► Connection wiring diagram and overall dimensions

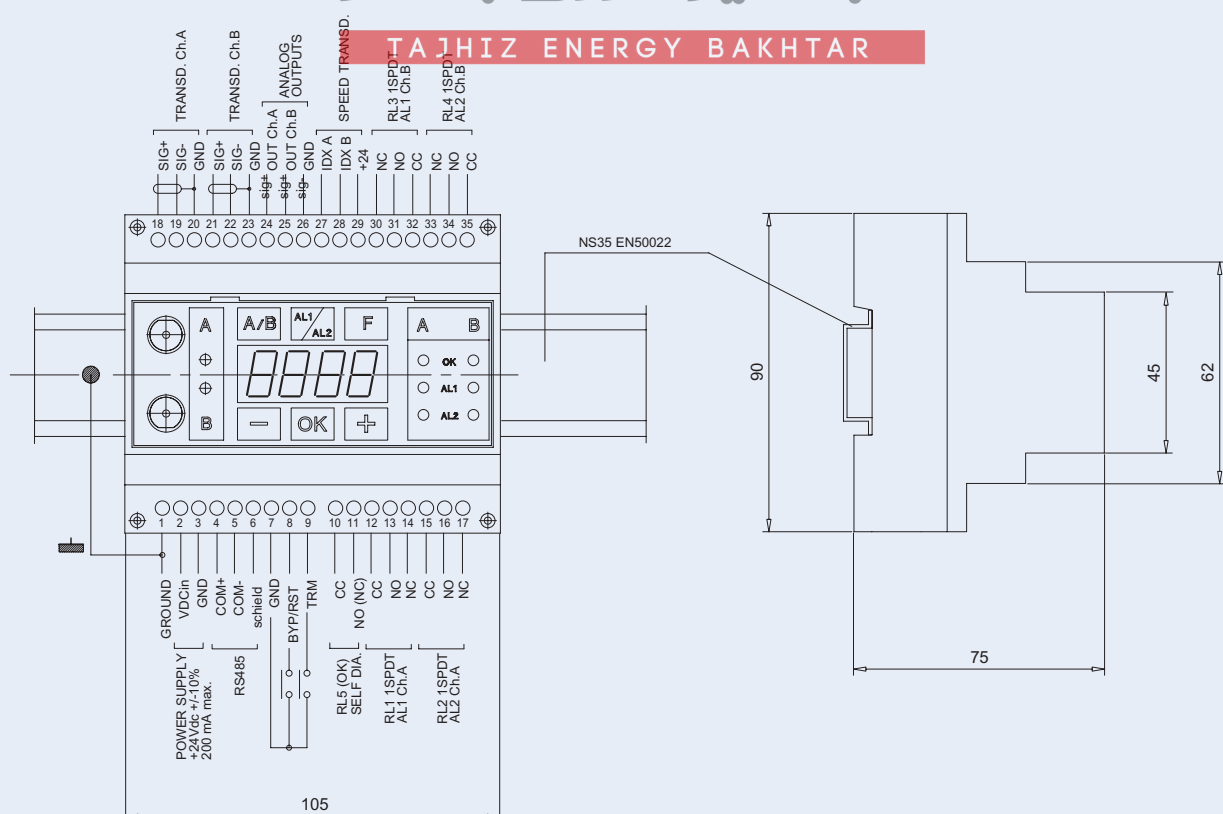

Composition:

- ▷ 1 instrument in plastic box
- ▷ 1 or 2 measuring traducers (velocity or acceleration transducer)
- ▷ 2 velocity transducers (optional)

Transducers which can be used:

- ▷ Velocity transducers T1-40; T1-40V; T1-40BF; T1-38; T1-38V; T1-38BF
- ▷ Acceleration transducers (ICP) TA 18; M16; M602

Power supply:

- ▷ 24 Vdc nominal (22÷26 Vdc)
- ▷ 110/220 Vac 50 to 60 Hz (optional)

External connection:

- ▷ Terminal board for connecting transducers (max. cable section 2.5 mm²)
- ▷ Terminal board for connecting alarm contacts (max. cable section 2.5 mm²)
- ▷ Terminal board for serial port RS485
- ▷ BNC connectors for connection to the analyzer

Ambient temperature range:

- ▷ -20° / +70°C

Inputs:

- ▷ 2 inputs, vibration transducers
- ▷ 2 inputs, velocity transducers
- ▷ 2 inputs for TRIP MULTIPLIER and BYPASS/RESET
- ▷ Serial link RS485

Analog outputs:

- ▷ 2 analog outputs 4:20 mA / 0: 10 V

Output relays:

- ▷ SPDT contacts, I level, channel A/B
- ▷ SPDT contacts, II level, channel A/B
- ▷ SPDT contact, self-diagnostics

Max. measuring range:

- ▷ velocity: 200 mm/s
- ▷ acceleration: 50g
- ▷ displacement: 1000 µm

Type of measurement:

- ▷ RMS, peak, peak-to-peak

Protection degree:

- ▷ IP30 EN 529/10.91



► TM1: example of multiple application

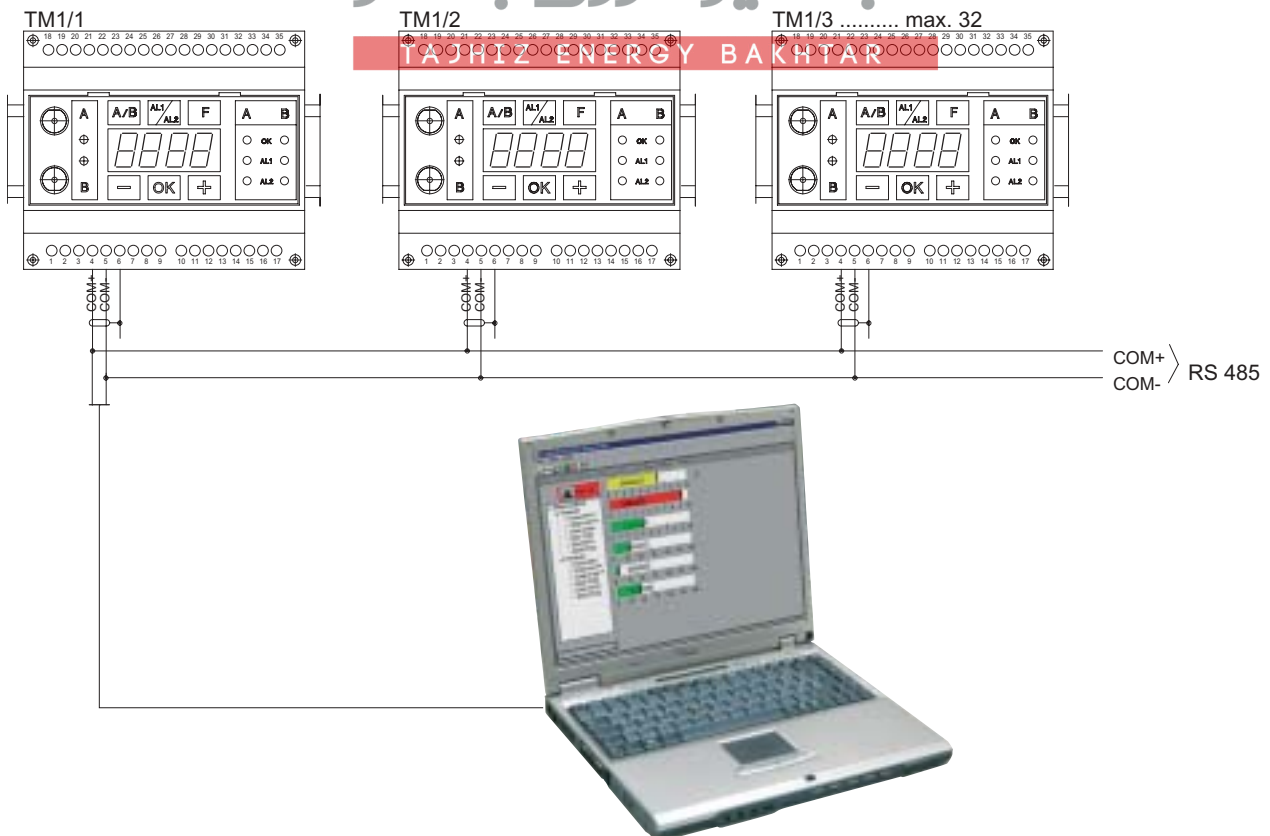

▶ ORDER INFORMATION

The TM1 equipment is supplied according to the configuration selected by the Customer. However the setting of the operating parameters can be varied during installation of the system by using the buttons on the control panel or via serial link RS485 using a PC provided with the appropriate program.

TM1 / A / B / C / D / E / F / G / H

▶ A: Type of transducer

- V velocity transducer
- A acceleration transducer

▶ B: Dimension measured

- 0 displacement
- 1 velocity
- 2 acceleration

▶ C: Mode of measurement

- 0 RMS
- 1 peak
- 2 peak-to-peak

▶ D: Range of measurement

- 0 0: 100 µm
- 1 0: 200 µm
- 2 0: 250 µm
- 3 0: 10 mm/sec
- 4 0: 20 mm/sec
- 5 0: 50 mm/sec
- 6 0: 1 g
- 7 0: 5 g
- 8 0: 10 g
- 9 0: 20 g
- S special to be defined

▶ E: High bandpass filter

- 0 without filter
- 1 5 Hz
- 2 10 Hz
- 3 20 Hz
- 4 50 Hz
- 5 100 Hz
- S special to be defined

▶ F: Low bandpass filter

N.B: The low pass filter frequency should be at least double that of the high bandpass filter

- 0 without filter
- 1 100 Hz
- 2 1000 Hz
- 3 2500 Hz
- 4 5000 Hz
- 5 10000 Hz
- S special to be defined

▶ G: Output signal

- 0 4: 20 mA
- 1 0: 20 mA
- 2 0: 10 V
- S special to be defined

▶ H: Power supply

- 0 24 Vdc
- 1 110/220 VAC 50÷60 Hz

▶ Order example:

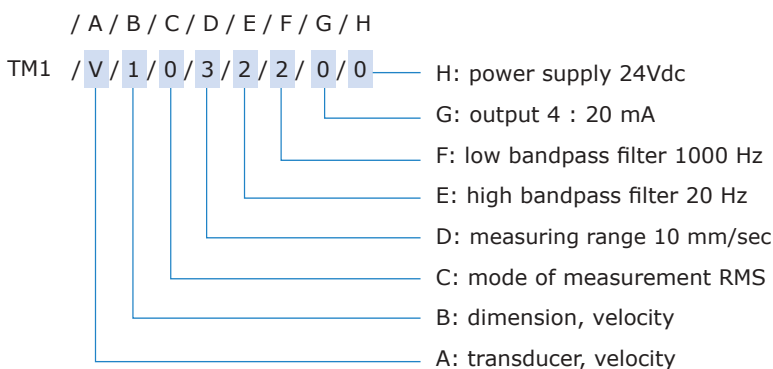

CEMB S.p.A.

Via Risorgimento, 9
23826 MANDELLO DEL LARIO (LC) Italy
www.cemb.com
e-mail: cemb@cemb.com

Vibration analysis division:

phone +39 0341 706111
fax +39 0341 735678
e-mail: stm@cemb.com



TAJHIZ ENERGY BAKHTAR

CEMB
BALANCING MACHINES



All the data and features mentioned in this catalogue are purely for information and do not constitute any commitment on the part of our company, which reserves the right to make any and all alterations it may consider suitable without notice.

